

FR and FD Luminaires

Nonmetallic Fluorescent

4 foot, 2 lamp fixtures. High-impact fiberglass reinforced polyester fixtures suitable for use in wet and damp locations.

NEC/CEC — FR Series
Wet Locations
IP65 when used with optional polycarbonate lens

NEC/CEC — FD Series
Class I, Division 2, Groups A, B, C, D
Class I, Zone 2, IIC

Applications

- For use in locations where a high degree of corrosion resistance is required.
- FR Series:
 - For use in areas where high humidity or water vapor are present
 - Typical uses include meat- or food-processing plants, dairy or drug plants, breweries, kitchens, chemical plants, car washes, laundries and parking garages.
 - Can be used indoors or outdoors in protected locations (wet locations).
 - Operates safely in 38 °C (100 °F) ambient temperature areas.
- FD Series:
 - For use in hazardous locations defined by the NEC as Class I, Division 2; and Class I, Zone 2.
 - For wet-location use where protection against dirt, water and moisture is necessary.
 - Typical applications include oil refineries, petrochemical facilities, pulp and paper mills, food-processing plants, warehouses, underground tunnels and general manufacturing facilities.
- FD Series fixture is UL listed for Class I, Division 2.

Features

- Fixtures are available with ballasts to support T12 and T8 lamps for nearly all U.S. and foreign voltage and frequency combinations.
- Low operating costs provide more lumens per Watt than incandescent fixtures.
- Housing is smooth, seamless, one-piece injection molded.
- Lens comes in high-impact polycarbonate plastic or impact-resistant acrylic.
- Fixtures are washable, non-conductive and corrosion-resistant.
- Enclosure is rated at IP65 (using polycarbonate lens), dust-proof and protected against water spray.
- A compressible, one-piece, non-thixotropic polyol gasket is bonded to the housing around the entire perimeter. It forms a continuous tight seal with the lens to keep out dirt, vapor and moisture.
- Lens is securely clamped to fixture using six captive corrosion-proof molded celcon tension latches. Lens is impact-resistant acrylic to protect lamps against breakage, and protect work area from broken lamp glass.
- Electrical components are mounted on a metallic wireway. Reflector is supported by internal safety springs to simplify installation and servicing.
- Optional fusing protects circuitry against occasional line voltage spikes.
- FR Series fixtures are available with one or two watertight 1/2" hubs for electrical-feed mounting or single-entry mounting.

Standard Materials

- Housing: fiberglass reinforced polyester
- Lens: polycarbonate or acrylic. (Fixture has IP65 rating with polycarbonate lens.) Acrylic lens supplied as standard
- Latches: celcon
- Ceiling mounting bracket: stainless steel
- Adjustable wall mount: copperfree (4/10 of 1% max.) aluminum
- Fixed wall mount: stainless steel



Illustrated Features

Non-thixotropic polyol gasket is bonded to housing. With plastic latches closed, it forms a continuous, tight seal with lens. Keeps out moisture, vapor and dirt. Allows fast, easy fixture washing.

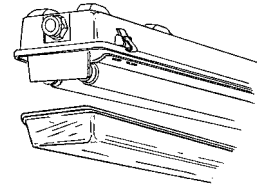

- Chain mount: zinc plated steel
- Gasket: non-thixotropic polyol
- Hubs: zinc plated steel with neoprene o-ring
- Lampholders: polycarbonate

Standard Finishes

- Housing: white color finish
- Celcon latches: white color finish
- Adjustable wall mount: epoxy powder coat

Options:

- Add Suffix **-F** for Fused
- Add Suffix **-T** for Terminal Blocks
- Add Suffix **-P** for Polycarbonate Lens for IP65 Rating
- Add Suffix **-E** for Emergency Battery Pack capability in moments of power interruption. Luminaire automatically switches to emergency mode, keeping two lamps illuminated for a minimum of 90 minutes. When AC power is restored, battery automatically recharges in 24 hours. Initial light output is 600-700 lumens.

NEC/CEC Compliances and Certifications

- FR Series:
 - UL Standard: UL 1598
 - UL Listed: E187946
 - CSA Standard: C22.2 No. 250
 - cUL Listed: E187946
- FD Series:
 - UL Standard: UL 1598, UL 844
 - UL Listed: E10794
 - CSA Standard: C22.2 No. 250, C22.2 No. 137
 - cUL Listed: E10794

FR and FD Luminaires

Nonmetallic Fluorescent

4 foot, 2 lamp fixtures. High-impact fiberglass reinforced polyester fixtures suitable for use in wet and damp locations.

NEC/CEC – FR Series

Wet Locations

IP65 when used with optional polycarbonate lens

NEC/CEC – FD Series

Class I, Division 2, Groups A, B, C, D

Class I, Zone 2, IIC

Order using catalog numbering guide below.

Catalog Numbering Guide For FR And FD Nonmetallic Fluorescent Lighting Fixtures

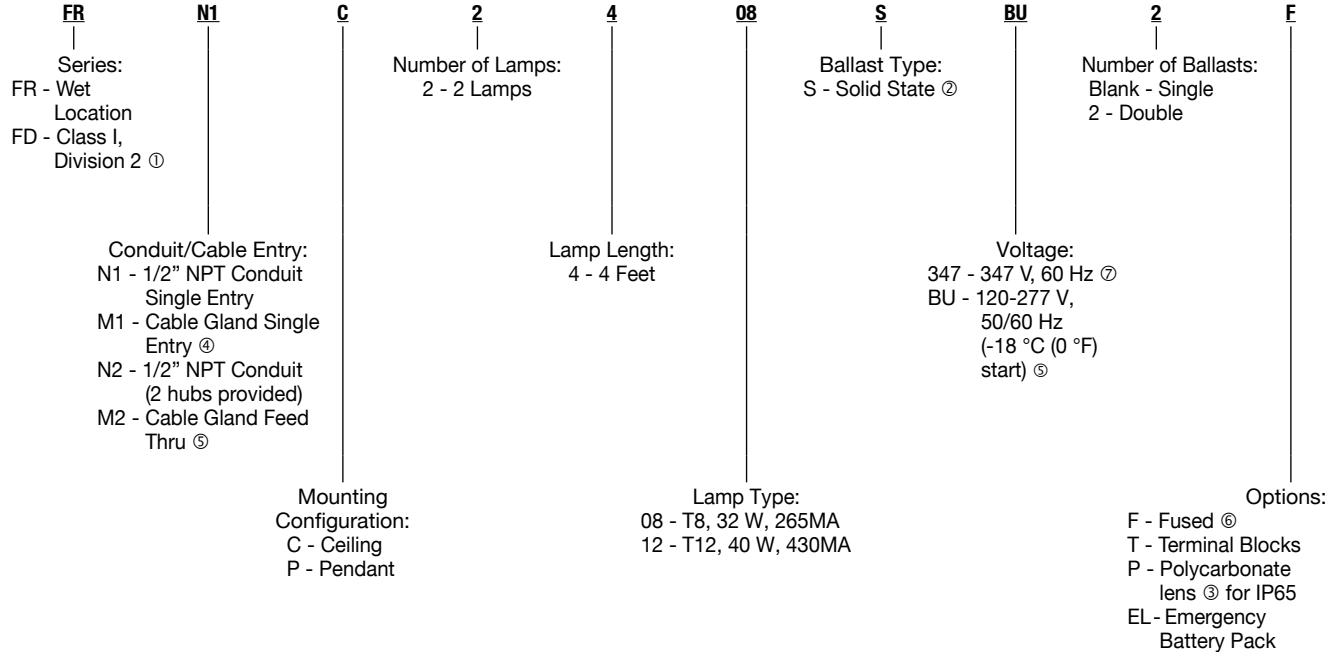

① Fixture is not available with M1 or M2 cable entry options

② Cold weather standard for T8.

③ Use polycarbonate lens for IP65 rating.

④ Fixture will be supplied with a 1.5 m (5') length of #14/3 cord and 3 prong plug (120 V) pre-installed when ordered with cable gland. Fixture with cable gland can only be used with hook and chain mounting.

⑤ T8-RS only.

⑥ Canadian Electrical Code does NOT allow fusing in hazardous locations.

⑦ Certified to meet the Canadian Electrical Code (CEC) only.

FR and FD Luminaires

Nonmetallic Fluorescent

4 foot, 2 lamp fixtures. High-impact fiberglass reinforced polyester fixtures suitable for use in wet and damp locations.

NEC/CEC – FR Series

Wet Locations

IP65 when used with optional polycarbonate lens







NEC/CEC – FD Series

Class I, Division 2, Groups A, B, C, D

Class I, Zone 2, IIC

Appleton

FLUORESCENT/AREA: NEC/CEC ENCLOSED AND GASKETED

Item	Description	Catalog Number
	1/2" NPT watertight conduit hub	FHUB
	Cable gland	FGLAND
	32 W (T8) and 40 W (T12) lampholder	FS0C40
	Standard plastic clips	FPCLIP
	Acrylic lens cover	FLENS
	Polycarbonate lens cover ①	FPLENS
Ceiling Mounting Bracket (Supplied standard with product)		
	Stainless steel bracket with mounting hardware (set of 2)	FBRACKET
Fixed 45° Wall Mount		
	11 gauge (1/8") stainless steel (set of 2)	FWWFM

① When used with FD series, fixture has an IP65 rating.

FR and FD Luminaires

Nonmetallic Fluorescent

4 foot, 2 lamp fixtures. High-impact fiberglass reinforced polyester fixtures suitable for use in wet and damp locations.

NEC/CEC — FR Series

Wet Locations

IP65 when used with optional polycarbonate lens

NEC/CEC — FD Series

Class I, Division 2, Groups A, B, C, D

Class I, Zone 2, IIC

Dimensions in Millimeters (Inches)

View of Fixture Cover

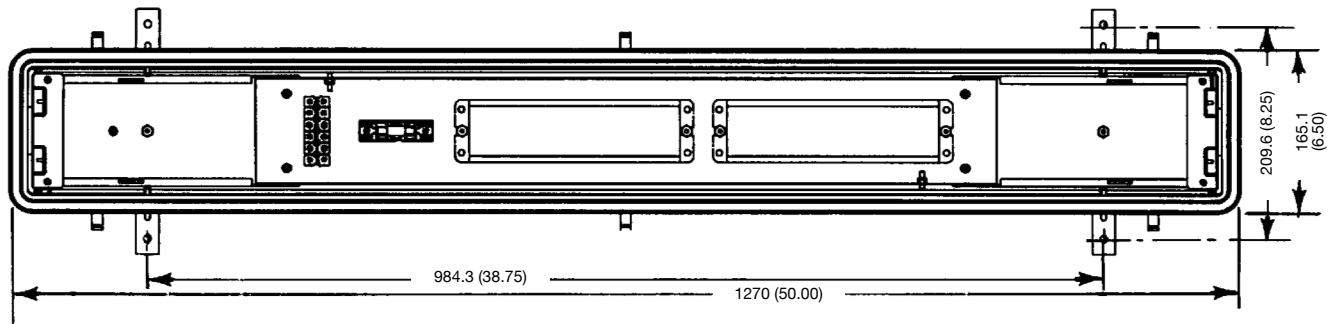

Side View

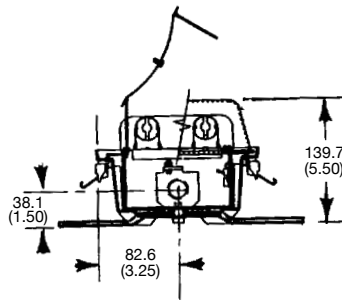

Fixed 45° Wall Mount — FVWFM

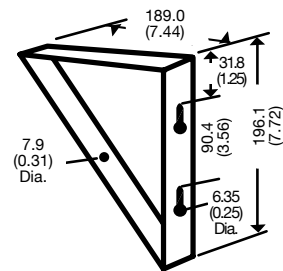

View of Fixture Mounting

